

- Ⓒ OPERATING INSTRUCTIONS
- Ⓕ INSTRUCTIONS
- Ⓓ BEDIENUNGSANLEITUNG
- Ⓔ INSTRUCCIONES DE EMPLEO
- Ⓘ ISTRUZIONI D'USO

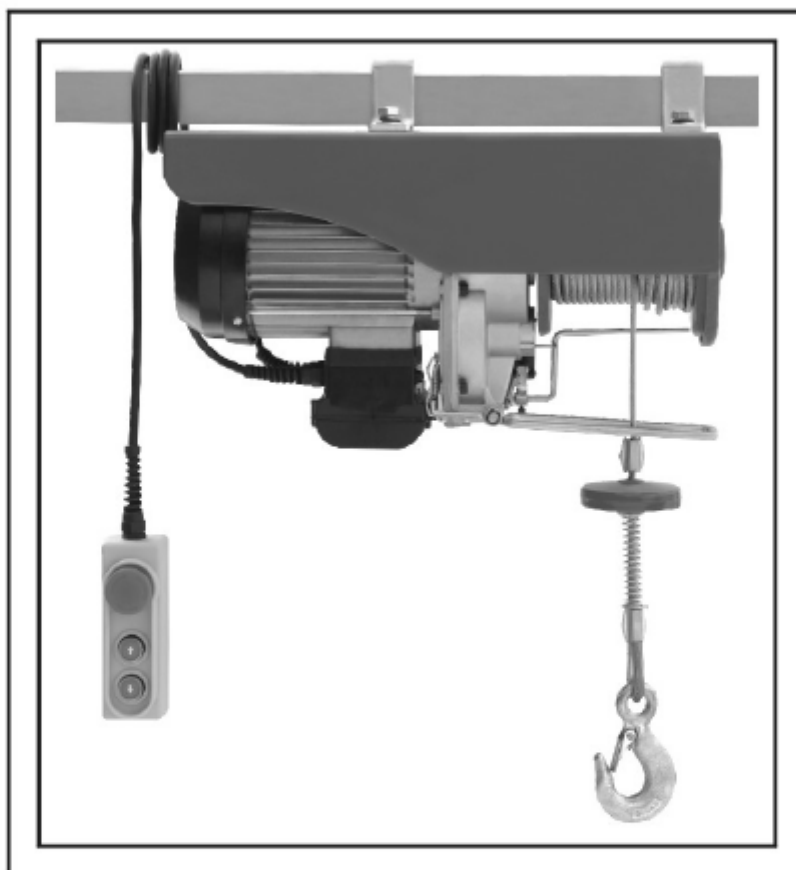

CABLE HOIST
PALAN
SEILWINDE
POLIPASTO
PARANCO

PA1000D

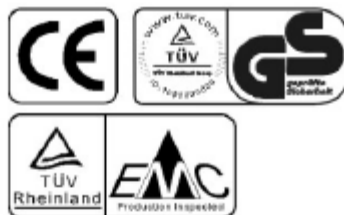
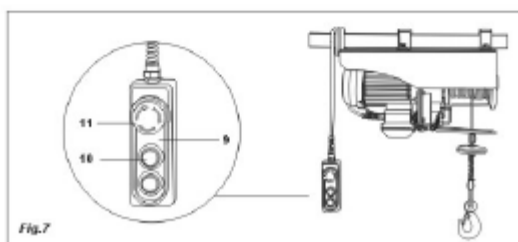
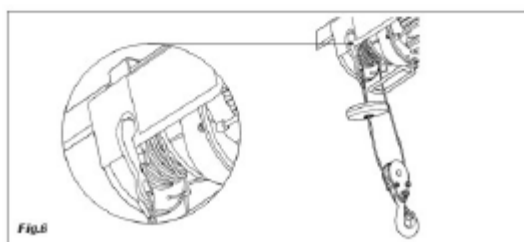
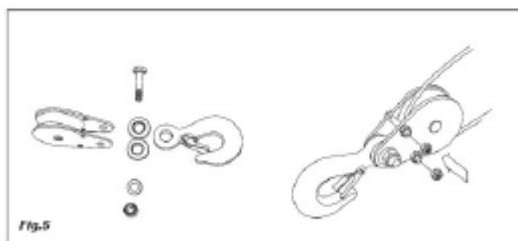
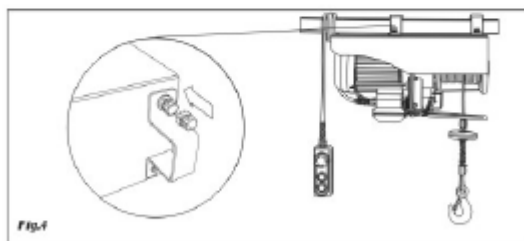
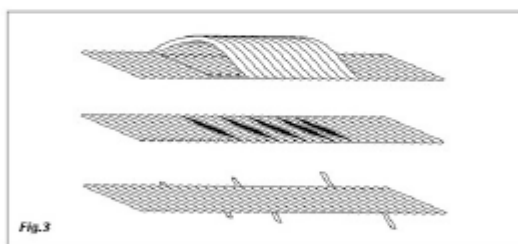
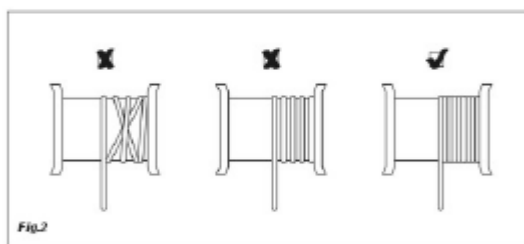
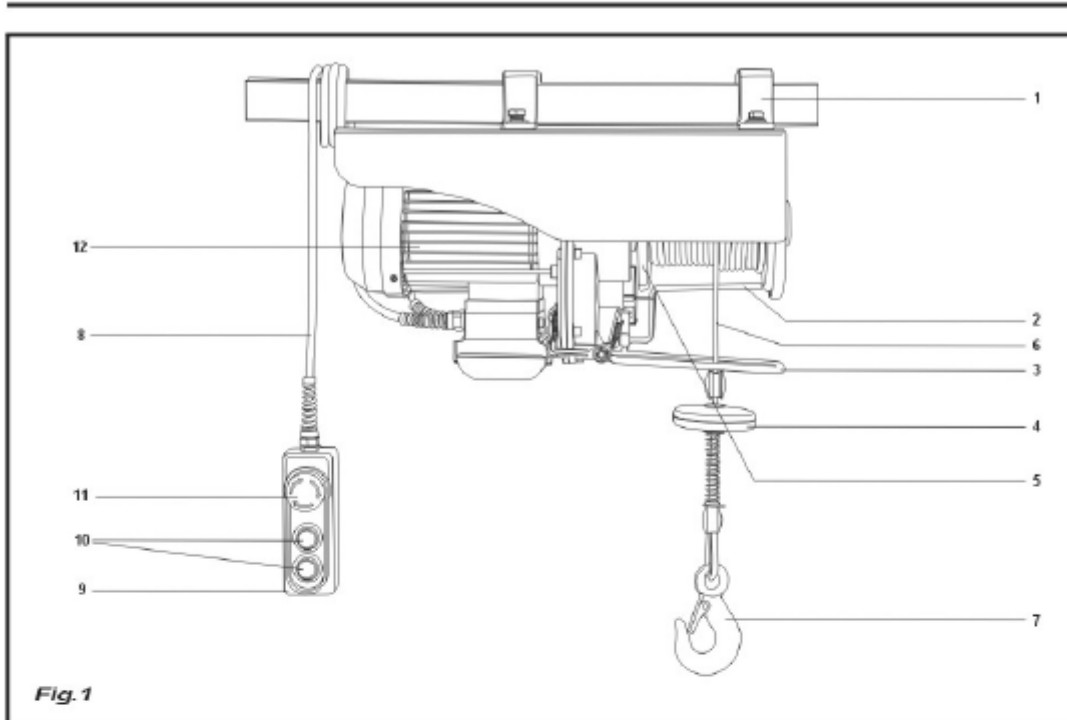

Electric Rope Hoist

The number in the following text correspond with the pictures Fig.1~Fig.7

Figure 1

- | | |
|--------------------|-----------------------------|
| 1. Bracket | 7. Hook |
| 2. Down limit pole | 8. Main cable |
| 3. Up limit lever | 9. Control handle |
| 4. Limit block | 10. Push button |
| 5. Rope drum | 11. (Emergency) Stop switch |
| 6. Steel rope | 12. Motor |

Technical specification

	PA1000D
Voltage	230V, 50Hz
Current (A)	7.4
Input power (W)	1600
Rated load (kg)	500/999
Lifting height (m)	12/6
Rated speed (m/min)*	8/4
Rope Diameter (mm)	5.6
Rope tensile strength (N/mm ²)	≥1770
Insulating grade	B
Protecting grade	IP54
Work rate**	S3 25%-10min
Group of mechanisms	M1
Net weight (kg)	31

*Rated speed is defined as the lowest speed of the electric rope hoist.

**Work rate e.g. S3-25%-10min: S3 = Intermittent periodic duty, meaning during a work period of 10 minutes the hoist may run max. 25% (i.e. 2.5 minutes).

General

1. The electric rope hoist is an ideal tool in your garage, warehouse or other similar locations for hoisting all kinds of loads.
2. This rope hoist can not be used for transporting hot molten masses. It can not be used for operating in aggressive environments and low temperatures.
3. The group of mechanisms is M1.
4. The useful life of the electric rope hoist is above 8000 cycles (except wearing parts). If the hoist has run 8000 cycles, it must have all mechanisms inspected and maintained.
5. Read and understand the instruction manual completely and clearly before using the hoist.
6. Ensure that operators know how the machine works and how it should be operated.
7. The user shall always work in compliance with the operating instructions.
8. The electric rope hoist is not designed for continuous use. The work rate is intermittent periodic duty.
9. The rated load of the machine does not vary with the position of the load.

Safety instructions

1. Always confirm that the service voltage corresponds to the voltage on the rating plate. Inappropriate supply voltage may result in working abnormally or personal injury.
2. Your socket plug must be grounded and at the same time, your power supply system must be supplied with a leakage circuit breaker.
3. It is forbidden to lift loads above the rated load of the hoist.
4. Use the device only for its intended purpose. Never carry persons with the hoist.
5. Do not disconnect the plug by pulling the cord. Keep the cord out of heat, oil and sharp edges.
6. Do not try to lift fixed or obstructed loads.
7. Pull out the plug when the hoist is not in use.
8. Keep children and other unauthorized persons away from the machine.
9. Do not side-pull loads. Avoid swinging the load or hook.

10. Make sure the hook travels at the direction same with your operation intention.
11. Inspect the electric rope hoist and switches regularly to make sure they are in good operating conditions.
12. Have your tool repaired by an expert; otherwise it may cause danger for the user.
13. Avoid excessive inching.
14. It is not allowed for you attention to be diverted from operating the hoist.
15. Do not stand or work under a lifted load.

Installation and use

Unpacking

After opening the carton, carefully inspect the hoist frame, cords, hooks and control units, etc. for damages, which may have occurred during shipment.

Installation (See Figure 4)

The hoist is provided with an installation system that allows it to be mounted on a rectangular beam.

The dimension of the rectangular beam must be in accordance with the position and dimension of the installation holes of the hoist and its strength can hold the rated load. It is recommended to turn to a skilled technician for help and inspect the solidity of the beam structure.

The fastening screw must be properly tightened. Before utilization, a skilled technician should check that the support system and the coupling of the hoist are well sized.

Utilization of pulley block (See Figure 5 and Figure 6.)

The hoist is provided with an extra pulley and hook, and when they are used correctly, the machine can hoist double load.

Assemble the pulley with help of bolts as shown in the picture.

The hook originally fixed on the machine can be attached to the rack's opening which is designed for this purpose. With help of 2 steel cables to lift the load, the machine is now capable of hoisting a double load.

Operating instructions

1. Before the machine is used for the first time, remove the adhesive tape for fixing

steel cables from the cable drum.

2. The value of the equivalent sound emission pressure level at the operator's position is lower than 85dB.
3. For the machine, the supplying power requirement is as follows: the voltage is rated voltage $\pm 10\%$ and the frequency is rated frequency $\pm 1\%$.
4. The hoist is used at ambient temperature of $0^{\circ}\text{C} \sim 40^{\circ}\text{C}$, and the relative humidity of air at 25°C is not higher than 85%. The sea level where it is used is not higher than 1000m.
5. The transportation and storage temperature of the hoist may be above -25°C and below 55°C , with the highest temperature of not higher than 70°C .
6. The user shall lift the load from the ground with the lowest speed. When a heavy weight is lifted from the ground, the steel cable shall be in tense state instead of slack state.
7. The motor of the hoist is equipped with a overheat switch. During operating, the hoist may stop running, and it will become operational again only after a break for the motor to cool down.
8. The electric rope hoist is not supplied with any overload stop. Therefore, if it is unable to lift a heavy weight, do not insist and let the motor cool down, since that means the load exceeds the maximum capacity of the hoist.
9. Do not leave a load supported by the hoist unattended unless specific precautions have been taken.
10. Provide a 10A fuse or 10A over-current protector to protect your power supply system.
11. Do not use limit switches as routine operating stop switches. They are only emergency devices.
12. Before using this hoist, make sure that the steel cable is correctly wound around the rope drum with the pitch equal to the diameter of the steel cable. (See Fig. 2).
13. Make sure that the load is properly secured to the lifting hook (7) or the pulley and the operator shall always keep certain distance with the load and the steel cable (6).

Operation

1. Check if the emergency stop switch (11) is pressed. Turn the red button clockwise to release it.

2. Press the push button ▲ (10) to lift the load
3. Press the push button ▼ (10) to lower the load
4. For the up limited system, when the hoisted load is almost at the top position, the limit block (4) will move the up limit lever (3) upwards, and then a switch in the motor will now be engaged to stop the upward movement of the motor.
5. For the down limited system, when the hoisted load is almost at the bottom position (about two turns of cable around the drum), the down limit pole (2) will move, and then another switch in the motor will make the downward movement of the motor stop. In case the moving direction is different with that it is being controlled (caused by the steel cable hold down by those directly beside it), the down limited system may also be actuated.
6. When the emergency stop switch is pressed, the hoist will be stopped.
7. In case of an emergency, immediately press the red emergency stop switch (11) to stop the machine. When the emergency stop switch is actuated, operating the hoist is not possible.

Circuit diagram

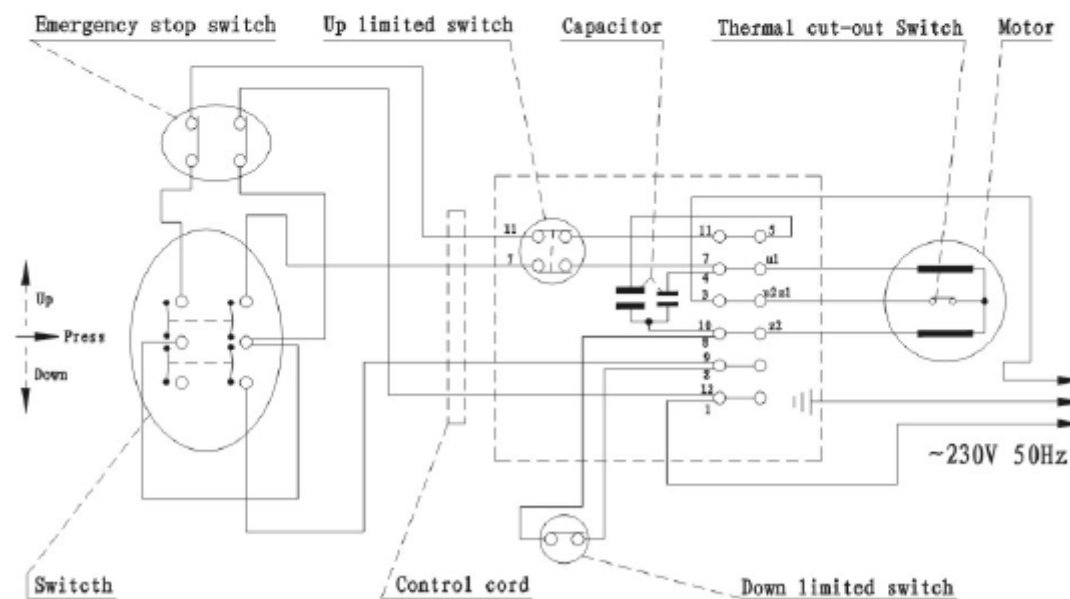

Periodic inspection and maintenance

Attention! Always make sure that the machine is not connected to the main electricity network before any mechanism maintenance is carried out.

1. Hereinafter, per cycle means that the operator operates the load up and down for one time. Periodic check means that a part needs to be inspected after the hoist working per 100 cycles.
2. Periodically make sure the limit switches function properly. The limited system should be tested as follows:
When the hoist is carrying out hoisting operation (without load), move the spacing collar (3) towards the rising direction, the motor of the machine must stop running.
When the hoist is carrying out lowering operation, move the down limit pole, the motor must stop running.
3. Periodically check the power cords and control cords.
4. Lubricate the steel cable and the pulley after per 200 cycles.
5. Confirm if the steel cable is in good operating mode after per 30 cycles. If there are any damages on the steel cable (see Figure 3), replace the steel cable immediately in accordance with the requirements in the technical data table.
6. Inspect if the screws securing the bracket and the pulley are well tightened after per 1000 cycles
7. Check the hook and the pulley after per 1000 cycles to ensure that they are in good operating modes.
8. Before using the electric rope hoist every time, inspect the emergency stop switch and its button panel to ensure they are in good operating modes.
9. Inspect the braking system after per 100 cycles. If there are abnormal noises in the motor or the hoist is unable to hold the rated load, the braking system must be overhauled.
10. Replace damaged and worn parts, and keep necessary maintenance record.
11. Contact an authorized service center for extraordinary maintenance.

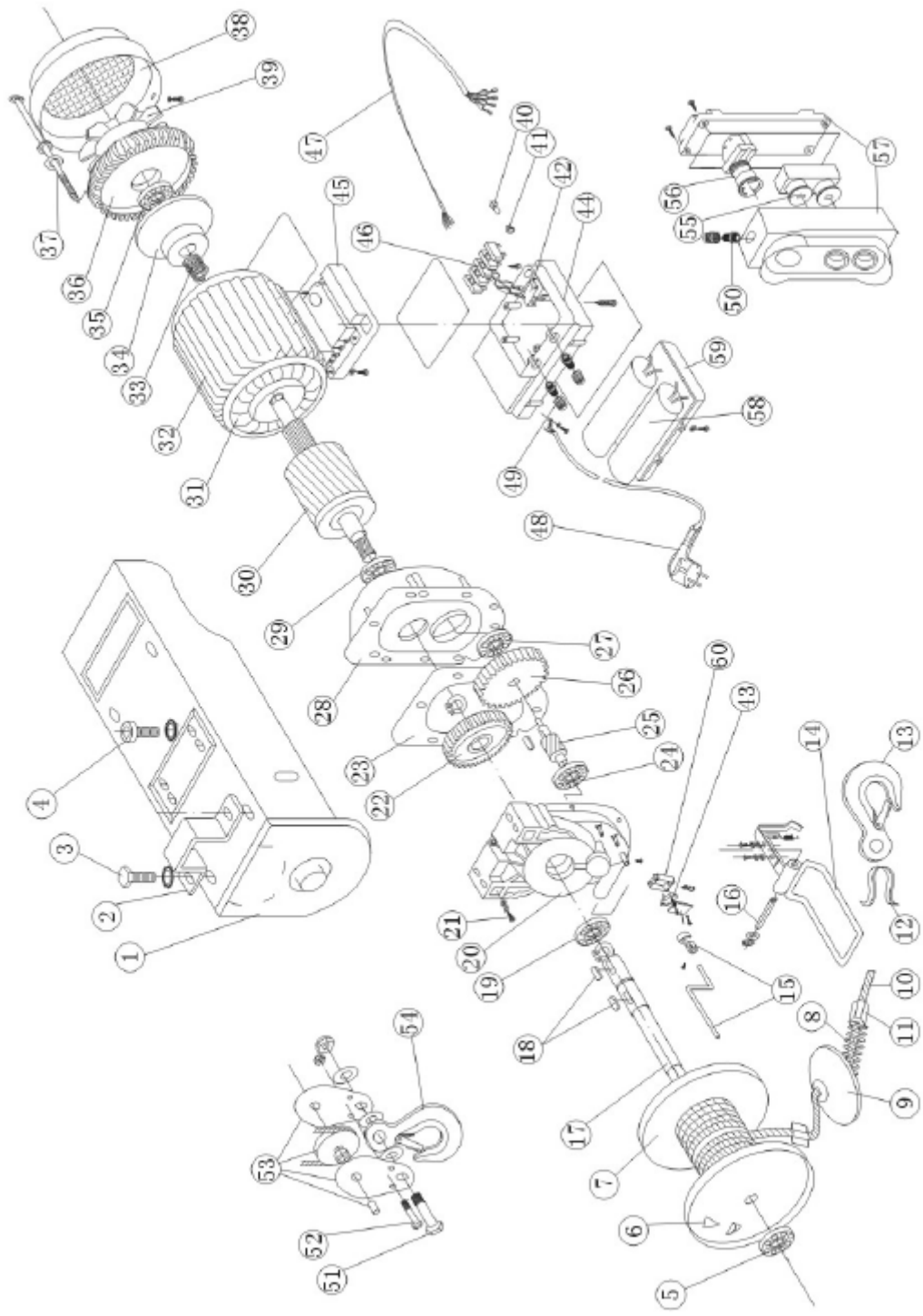

PA SERIES ELECTRIC ROPE HOIST LIST

No.	Description	Qua.	No.	Description	Qua.
1	Bracket	1	31	Stator	1
2	Fixing Ring	2	32	Chassis	1
3	Hexagon Bolt	4	33	Brake Spring	1
4	Socket Cap Screws	2	34	Brake Assembly	1
5	Bearing	1	35	Bearing	1
6	Embed Pin	2	36	Motor Cover	1
7	Rope Drum	1	37	Extra Long Hexagon Bolt	4
8	Spring Buffer	1	38	Fan Cover	1
9	Limit Block	1	39	Fan Blade	1
10	Steel Cable	1	40	Limit Switch Contactor	2
11	Fastening Sleeve of Rope	2	41	Limit Shaft Seal	2
12	Shrink-Ring of Rope	1	42	Up Limit Switch	1
13	Hook	1	43	Down Limit Switch	1
14	Limit Lever Assy.	1	44	Connection Box	1
15	Down Limit Pole	1	45	Base of Connection Box	1
16	Socket Cap Screws	1	46	Terminal Block	1
17	Rope drum Shaft	1	47	Four Core Cable	1
18	Flat Pin	1	48	Plug	1
19	Bearing	1	49	Cord Clip (Small)	1
20	Gear Box	1	50	Cord Clip (Big)	2
21	Cap Screws	8	51	Hook Shaft	2
22	Second Stage Gear	1	52	Anti-Slip Screw	2
23	Paper Seal	1	53	Pulley Assembly	1
24	Bearing	1	54	Hook for Pulley	1
25	Middle Shaft	1	55	Positive and Negative Switch	1
26	First Stage Gear	1	56	Emergency Stop Switch	1
27	Bearing	1	57	Handle	1
28	Front Cover	1	58	Capacitor	1
29	Bearing	1	59	Connecting Housing Cover	1
30	Rotor	1	60	Down limit Box	1